

Unit – 4

Design of Beams

In this chapter, it is intended to learn the method of designing the beams using the principles developed in previous chapters. Design consists of selecting proper materials, shape and size of the structural member keeping in view the economy, stability and aesthetics. The design of beams are done for the limit state of collapse and checked for the other limit states. Normally the beam is designed for flexure and checked for shear, deflection, cracking and bond.

Design procedure

The procedure for the design of beam may be summarized as follows:

1. Estimation of loads
2. Analysis
3. Design

1. Estimation of loads

The loads that get realized on the beams consists of the following:

- a. Self weight of the beam.
- b. Weight of the wall constructed on the beam
- c. The portion of the slab loads which gets transferred to the beams. These slab loads are due to live loads that are acting on the slab dead loads such as self weight of the slab, floor finishes, partitions, false ceiling and some special fixed loads.

The economy and safety of the beams achieved depends on the accuracy with which the loads are estimated.

The dead loads are calculated based on the density whereas the live loads are taken from IS: 875 depending on the functional use of the building.

2. Analysis

For the loads that are acting on the beams, the analysis is done by any standard method to obtain the shear forces and bending moments.

3. Design

- a. Selection of width and depth of the beam.

The width of the beam selected shall satisfy the slenderness limits specified in IS 456 : 2000 clause 23.3 to ensure the lateral stability.

- b. Calculation of effective span (l_e) (Refer clause 22.2, IS 456:2000)
- c. Calculation of loads (w)

- d. Calculation of critical moments and shears.

The moment and shear that exists at the critical sections are considered for the design. Critical sections are the sections where the values are maximum. Critical section for the moment in a simply supported beam is at the point where the shear force is zero. For continuous beams the critical section for the +ve bending moment is in the span and –ve bending moment is at the support. The critical section for the shear is at the support.

- e. Find the factored shear (V_u) and factored moment (M_u)

- f. Check for the depth based on maximum bending moment.

Considering the section to be nearly balanced section and using the equation Annexure G, IS 456-2000 obtain the value of the required depth $d_{required}$. If the assumed depth “d” is greater than the “ $d_{required}$ ”, it satisfies the depth criteria based on flexure. If the assumed section is less than the “ $d_{required}$ ”, revise the section.

- g. Calculation of steel.

As the section is under reinforced, use the equation G.1.1.(b) to obtain the steel.

- h. Check for shear.

- i. Check for developmental length.

- j. Check for deflection.

- k. Check for $A_{st \min}$, $A_{st \max}$ and distance between the two bars.

Anchorage of bars or check for development length

In accordance with clause 26.2 IS 456 : 2000, the bars shall be extended (or anchored) for a certain distance on either side of the point of maximum bending moment where there is maximum stress (Tension or Compression). This distance is known as the development length and is required in order to prevent the bar from pulling out under tension or pushing in under compression. The development length (L_d) is given by

$$L_d = \frac{\phi \sigma_s}{4 Z_{bd}}$$

where, ϕ = Nominal diameter of the bar

σ_s = Stress in bar at the section considered at design load

Z_{bd} = Design bond stress given in table 26.2.1.1 (IS 456 : 2000)

Table 26.2.1.1: Design bond stress in limit state method for plain bars in tension shall be as below:

Grade of concrete	M 20	M 25	M 30	M 35	M 40 and above
Design bond stress τ_{bd} N/mm ²	1.2	1.4	1.5	1.7	1.9

Note: Due to the above requirement it can be concluded that no bar can be bent up or curtailed upto a distance of development length from the point of maximum moment.

Due to practical difficulties if it is not possible to provide the required embedment or development length, bends hooks and mechanical anchorages are used.

Flexural reinforcement shall not be terminated in a tension zone unless any one of the following condition is satisfied:

- a. The shear at the cut-off points does not exceed two-thirds that permitted, including the shear strength of web reinforcement provided.
- b. Stirrup area in excess of that required for shear and torsion is provided along each terminated bar over a distance from the cut-off point equal to three-fourths the effective depth of the member. The excess stirrup area shall be not less than $0.4bs/f_y$, where b is the breadth of the beam, s is the spacing and f_y is the characteristic strength of reinforcement in N/mm^2 . The resulting spacing shall not exceed $d/8\beta_b$ where β_b is the ratio of the area of bars cut-off to the total area of bars at the section, and d is the effective depth.
- c. For 36 mm and smaller bars, the continuing bars provide double the area required for flexure at the cut-off point and the shear does not exceed three-fourths that permitted.

Positive moment reinforcement:

- a. At least one-third the positive moment reinforcement in simple members and one-fourth the positive moment reinforcement in continuous members shall extend along the same face of the member into the support, to a length equal to $L_d/3$.
- b. When a flexural member is part of the primary lateral load resisting system, the positive reinforcement required to be extended into the support as described in (a) shall be anchored to develop its design stress in tension at the face of the support.
- c. At simple supports and at points of inflection, positive moment tension reinforcement shall be limited to a diameter such that L_d computed for f_d by 26.2.1 IS 456:2000 does not exceed.

$$\frac{M_1}{V} + L_0$$

where, M_1 = moment of resistance of the section assuming all reinforcement at the section to be stressed to f_d ;

$f_d = 0.87f_y$ in the case of limit state design and the permissible stress σ_{st} in the case of working stress design;

V = shear force at the section due to the design loads;

L_0 = sum of the anchorage beyond the centre of the support and the equivalent anchorage value of any hook or mechanical anchorage at simple support; and

at a point of inflection, L_0 is limited to the effective depth of the members or 12ϕ , whichever is greater; and

ϕ = diameter of bar.

The value of M_1/V in the above expression may be increased by 30 percent when the ends of the reinforcement are confined by a compressive reaction.

Negative moment reinforcement:

At least one third of the total reinforcement provided for negative moment at the support shall extend beyond the point of inflection for a distance not less than the effective depth of the member of 12ϕ or one-sixteenth of the clear span whichever is greater.

Anchorage of bars

Anchoring of bars is done to provide the development length and maintain the integrity of the structure.

Anchoring bars in tension:

- a. Deformed bars may be used without end anchorages provided development length requirement is satisfied. Hooks should normally be provided for plain bars in tension.
- b. Bends and hooks – shall conform to IS 2502
 1. Bends – The anchorage value of bend shall be taken as 4 times the diameter of the bar for each 45° bend subject to a maximum of 16 times the diameter of the bar.
 2. Hooks – The anchorage value of a standard U-type hook shall be equal to 16 times the diameter of the bar.

Anchoring bars in compression:

The anchorage length of straight bar in compression shall be equal to the development length of bars in compression as specified in clause 26.2.1 of IS 456:2000. The projected length of hooks, bends and straight lengths beyond bends if provided for a bar in compression, shall only be considered for development length.

Mechanical devices for anchorage:

Any mechanical or other device capable of developing the strength of the bar without damage to concrete may be used as anchorage with the approval of the engineer-in-charge.

Anchoring shear reinforcement:

- a. Inclined bars – The development length shall be as for bars in tension; this length shall be measured as under:
 1. In tension zone, from the end of the sloping or inclined portion of the bar, and
 2. In the compression zone, from the mid depth of the beam.
- b. Stirrups – Notwithstanding any of the provisions of this standard, in case of secondary reinforcement, such as stirrups and transverse ties, complete development lengths and anchorages shall be deemed to have been provided when the bar is bent

through an angle of at least 90° round a bar of at least its own diameter and is continued beyond the end of the curve for a length of at least eight diameters, or when the bar is bent through an angle of 135° and is continued beyond the end of the curve for a length of at least six bar diameters or when the bar is bent through an angle of 180° and is continued beyond the end of the curve for a length of at least four bar diameters.

Reinforcement requirements

1. Minimum reinforcement:

The minimum area of tension reinforcement shall be not less than that given by the following:

$$\frac{A_s}{bd} = \frac{0.85}{f_y}$$

where, A_s = minimum area of tension reinforcement.

b = breadth of beam or the breadth of the web of T-beam,

d = effective depth, and

f_y = characteristic strength of reinforcement in N/mm^2

2. Maximum reinforcement – The maximum area of tension reinforcement shall not exceed $0.04bD$

Compression reinforcement:

The maximum area of compression reinforcement shall not exceed $0.04bD$. Compression reinforcement in beams shall be enclosed by stirrups for effective lateral restraint.

Pitch and diameter of lateral ties:

The pitch of shear reinforcement shall be not more than the least of the following distances:

1. The least lateral dimension of the compression members;
2. Sixteen times the smallest diameter of the longitudinal reinforcement bar to be tied;
and
3. 300 mm.

The diameter of the polygonal links or lateral ties shall be not less than one-fourth of the diameter of the largest longitudinal bar, and in no case less than 16 mm.

Slenderness limits of beams to ensure lateral stability

A beam is usually a vertical load carrying member. However, if the length of the beam is very large it may bend laterally. To ensure lateral stability of a beam the following specifications have been given in the code.

A simply supported or continuous beam shall be so proportioned that the clear distance between the lateral restraints does not exceed $60b$ or $\frac{250b^2}{d}$ whichever is less, where d is the effective depth of the beam and b the breadth of the compression face midway between the lateral restraints.

For a cantilever, the clear distance from the free end of the cantilever to the lateral restraint shall not exceed $25b$ or $\frac{100b^2}{d}$ whichever is less.

Problems:

1. Design a singly reinforced SSB of clear span 5m to support a working live load of 25 kN/m run. Use Fe 415 steel and M 20 grad concrete. Assume the support thickness as 230 mm.

Step 1 (a): Fixing up the depth of the section.

Taking $\frac{L}{d} = 20$, for SSB [Refer 23.2.1, pg 37]

$$d = \frac{L}{20} = \frac{5}{20} = 0.25 \text{ m} = 250 \text{ mm}$$

Providing a cover of 25 mm, overall depth $D = 250 + 25 = 275 \text{ mm}$

Dimensions of the section.

Width $b = 230 \text{ mm}$

depth $d = 250 \text{ mm}$

Step 1 (b): Check for lateral stability/lateral buckling

Refer page 39, clause 23.3

Allowable $l = 60b$ or $\frac{250 b^2}{d}$

Allowable $l = 60b = 13800 \text{ mm} = 13.8 \text{ m}$

Or $\frac{250 b^2}{d} = 52900 \text{ mm} = 52.9 \text{ m}$

Allowable $l =$ Lesser of the two values

$$= 13.8 \text{ m}$$

Actual l of the beam (5m) < Allowable value of l . Hence ok

Step 2: Effective span

Referring class 22.2 page 34,

Effective span $l_e = \text{clear span} + d$

$$\begin{aligned}\text{Or } l_e &= \text{clear span} + \frac{1}{2} \text{ support thickness} + \frac{1}{2} \text{ support thickness} \\ &= \text{clear span} + \frac{t_s}{2} + \frac{t_s}{2}\end{aligned}$$

Whichever is lesser.

$$l_e = 5000 + 250 \text{ mm} = 5250 \text{ mm}$$

$$\text{Or } l_e = 5000 + \frac{230}{2} + \frac{230}{2} = 5230 \text{ mm}$$

Therefore $l_e = 5230 \text{ mm}$

Step 3: Calculation of loads:

Consider 1m length of the beam

a. Dead load = $(0.23 \times 0.275 \times 1\text{m} \times 25 \text{ kN/m}^3) = 1.58 \text{ kN/m}$

b. Live load = 25 kN/m

Total working load $w = 26.58 \text{ kN/m}$

Factored load = 26.58×1.5

$$W_u = 39.87 \text{ kN/m} \approx 40 \text{ kN/m}$$

$$\text{Factored moment } M_u = \frac{W_u \times l_e^2}{8} = \frac{40 \times 5.23^2}{8} = 136.76 \text{ kN-m}$$

$$\text{Factored shear} = \frac{40 \times 5.23}{2} = 104.6 \text{ kN}$$

Step 4: Check for depth based on flexure or bending moment consideration

Assuming the section to be nearly balanced, and equating M_u to M_{ulim} ,

$$M_u = M_{ulim} = 136.76 \text{ kN-m}$$

Using the equation G 1.1 (c), Annexure G IS 456-2000

$$M_{ulim} = 0.36 \frac{x_{u\max}}{d} \left(1 - 0.42 \frac{x_{u\max}}{d}\right) b d^2 f_{ck}$$

$$136.76 \times 10^6 = 0.36 \times 0.48 (1 - 0.42 \times 0.48) 230 d^2 \times 20$$

$$d = 464.21 \text{ mm}$$

Assumed depth d is less than the required depth of 464 mm. Hence revise the section

Assume

$$d = 500 \text{ mm}$$

$$b = 230 \text{ mm}$$

Loads:

$$\text{Dead load} = 0.23 \times 0.525 \times 1 \times 25 = 2.875 \text{ kN/m}$$

$$\text{Live load} = 25 \text{ kN/n}$$

$$\text{Total working load} = 27.875 \text{ kN/m}$$

$$\text{Factored load} = 27.875 \times 1.5 = 41.8 \approx 42 \text{ kN/m}$$

$$\text{Factored moment } M_u = \frac{W_u \times l_e^2}{8} = \frac{42 \times 5.23^2}{8} = 143.6 \text{ kN-m}$$

$$\text{Factored shear} = \frac{42 \times 5.23}{2} = 109.83 \text{ kN}$$

Check for depth based on flexure

$$M_u = M_{ulim} = 143.6 \text{ kN-m}$$

Using the equation G 1.1 (c)

$$M_{ulim} = 0.36 \frac{x_{umax}}{d} \left(1 - 0.42 \frac{x_{umax}}{d} \right) b d^2 f_{ck}$$

$$143.6 \times 10^6 = 0.36 \times 0.48 \left(1 - 0.42 \times 0.48 \right) 230 d^2 \times 20$$

$$d = 475.68 \text{ mm}$$

Assumed depth is greater than the required depth of 475.68 mm.

Required 'd' = 476 mm and Assumed 'd' = 500 mm

Hence ok.

Therefore we shall continue with $d = 500 \text{ mm}$ and $D = 525 \text{ mm}$

Check whether the section is under reinforced

$$\text{Actual moment acting } M_u = 143.6 \text{ kM-m}$$

Using equation G 1.1 (c)

$$M_{ulim} = 0.36 \frac{x_{umax}}{d} \left(1 - 0.42 \frac{x_{umax}}{d} \right) b d^2 f_{ck}$$

$$M_{ulim} = 0.36 \times 0.48 (1 - 0.42 \times 0.48) 230 \times 500^2 \times 20$$

$$= 158.66 \text{ kN-m}$$

$$M_u < M_{ulim}$$

Hence the section is under reinforced

Step 5: Calculation of steel:

Since the section is under reinforced we have,

Using equation G 1.1 (b)

$$M_u = 0.87 f_y A_{st} d \left(1 - \frac{A_{st} f_y}{bd f_{ck}} \right)$$

$$143.6 \times 10^6 = 0.87 \times 415 \times A_{st} \times 500 \left(1 - \frac{A_{st} \times 415}{230 \times 500 \times 20} \right)$$

Solving the quadratic equation, $A_{st} = 960.33 \text{ mm}^2 \approx 960 \text{ mm}^2$

Choosing 8 mm diameter bars,

$$\text{Area of 1 bar} = \frac{\pi}{4} \times 8^2 = 50.265 \text{ mm}^2$$

Therefore number of bars of 8mm required = $19.10 = 20$ bars

Distance between any two bars

Minimum distance between two bars is greater of the following:

- Size of the aggregate + 5 mm
20 mm + 5 mm
- Size of the bar (whichever is greater)

Therefore minimum distance = 25 mm

$$\text{Distance between bars} = \frac{230 - 2 \times 25 - 2 \times 8}{19} = 8.63$$

$8.63 < 25$. Therefore 8 mm dia bars cannot be provided.

Let us choose 16 mm dia bars.

$$\text{Area of 1 bar} = \frac{\pi}{4} \times 16^2 = 201.06 \text{ mm}^2$$

Therefore number of bars of 16 mm required = $4.77 = 5$ bars

$$\text{Distance between bars} = \frac{230 - 2 \times 25 - 2 \times 8 - 5 \times 16}{4} = 21 \text{ mm}$$

Minimum distance required = 25 mm

Therefore 16 mm dia cannot be used.

Let us choose 25 mm dia bars.

$$\text{Area of 1 bar} = \frac{\pi}{4} \times 25^2 = 490.890 \text{ mm}^2$$

Therefore number of bars of 25mm required = 1.95 = 2 bars

$$\text{Distance between the bars} = \frac{230 - 2 \times 25 - 2 \times 8 - 2 \times 25}{1} = 114 \text{ mm}$$

Check for $A_{st \text{ min}}$

$$A_{st \text{ min}} = \frac{0.85bd}{0.87f_y}$$

$$A_{st \text{ min}} = \frac{0.85 \times 230 \times 500}{0.87 \times 415} = 270.7 \text{ mm}^2$$

Check for $A_{st \text{ max}}$

$$A_{st \text{ max}} = 0.04 \times b \times D = 4830 \text{ mm}^2$$

$$A_{st \text{ provided}} = 982 \text{ mm}^2$$

$$A_{st \text{ min}} < A_{st} < A_{st \text{ max}}$$

Hence ok.

Check for shear

Factored load = 42 kN/m

$$\text{Support reaction} = \frac{wl}{2} = \frac{42 \times 5}{2} = 105 \text{ kN}$$

$$V_u = 105 \text{ kN}$$

$$\tau_v = \frac{V_u}{bd} = 0.913 \text{ N/mm}^2$$

$$P_t = \frac{100A_{st}}{bd} = \frac{100 \times 982}{230 \times 500} = 0.8539$$

From table 19, IS 456-2000 page 73

$$\tau_c = 0.58 \text{ N/mm}^2$$

From table 20, IS 456-2000 page 73

$$\tau_{c \text{ max}} = 2.8 \text{ N/mm}^2$$

$$\tau_c < \tau_v < \tau_{c \max}$$

Hence design of shear reinforcement is required

Selecting 2 leg vertical stirrups of 8 mm diameter, Fe 415 steel,

$$A_{sv} = 2 \times \frac{\pi}{4} \times 8^2 = 100 \text{ mm}^2$$

V_c = Shear force taken up by the concrete

$$= \frac{\tau_c b d}{1000} = \frac{0.28 \times 230 \times 500}{1000} = 66.7 \text{ kN}$$

$$V_u = 105 \text{ kN}$$

$$V_{us} = V_u - V_c$$

$$= 105 - 66.7 = 38.3 \text{ kN}$$

$$V_{us} = \frac{0.87 \times f_y \times A_{sv} \times d}{S_v} \text{ from clause 40.4}$$

$$38.3 \times 10^3 = \frac{0.87 \times 415 \times 100 \times 500}{S_v}$$

$$S_v = 471.3 \text{ mm}$$

Check for maximum spacing

Maximum spacing = 0.75d or 300mm whichever is lesser

Maximum spacing = 375 or 300mm

Therefore maximum spacing allowed = 300mm

Let us provide 8 mm dia 2-leg vertical stirrups at a spacing of 300 mm.

Check for $A_{sv \min}$:

$$A_{sv \text{ provided}} = 100 \text{ mm}^2$$

$$A_{sv \min} = \frac{0.4bS_v}{0.87f_y} = 76.44 \text{ mm}^2$$

$$A_{sv \text{ provided}} > A_{sv \min}$$

Hence ok.

Check for deflection:

$$\text{Allowable } \frac{l}{d} = \text{Basic } \frac{l}{d} \times M_t \times M_c \times M_f$$

Basic $\frac{l}{d} = 20$ as the beam is simply supported

To determine M_t

$$f_s = 0.58 \times 415 \times \frac{960}{982} = 235.3 \text{ N/mm}^2$$

from fig 4, $M_t = 1$

To determine M_c

From fig 5, $M_c = 1$ [since there is no compression reinforcement]

To determine M_f

$$\frac{b_w}{b_f} = 1 \quad [\text{since it is rectangular section } b_w = b_f]$$

Therefore allowable $l/d = 20 \times 1 \times 1 \times 1 = 20$

$$\text{Actual } l/d = \frac{5230}{500} = 10.46 < \text{Allowable } l/d.$$

Hence ok.

2. Design a cantilever beam of clear span 2m subjected to a factored live load of 30 kN/m run. Use M 20 grade concrete and Fe 415 steel. The cantilever forms the end of a continuous beam. Support thickness = 230mm

Step 1 (a): Fixing up the depth of the section.

Taking $\frac{L}{d} = 7$, for cantilever [Refer 23.2.1, pg 37]

$$d = \frac{L}{7} = \frac{2000}{7} = 285.7 \text{ mm}$$

However provide $d = 450 \text{ mm}$

Providing a cover of 25 mm, overall depth $D = 450 + 25 = 475 \text{ mm}$

Dimensions of the section.

Width $b = 230 \text{ mm}$

Depth $d = 450 \text{ mm}$

Step 1 (b): Check for lateral stability/lateral buckling

Refer page 39, class 23.3

$$\text{Allowable } l = 25b \text{ or } \frac{100 b^2}{d}$$

$$\text{Allowable } l = 25b = 5750 \text{ mm} = 5.75 \text{ m}$$

$$\text{Or } \frac{100 b^2}{d} = 11750 \text{ mm} = 11.75 \text{ m}$$

Allowable l = Lesser of the two values

$$= 5.75 \text{ m}$$

Actual l of the beam (5m) < Allowable value of l .

Hence ok

Step 2: Effective span

Referring class 22.2 page 34,

Effective span l_e = clear span + d

$$\text{Or } l_e = \text{clear span} + \frac{1}{2} \text{ support thickness}$$

$$= \text{clear span} + \frac{t_s}{2}$$

Whichever is lesser.

$$L_e = 2 \text{ m} + 450 \text{ mm} = 2450 \text{ mm}$$

$$\text{Or } L_e = 2 \text{ m} + \frac{230}{2} = 2115 \text{ mm}$$

Therefore $l_e = 2115 \text{ mm}$

Step 3: Calculation of loads

Consider 1m length of the beam

- Dead load = $(0.23 \times 0.475 \times 1 \text{ m} \times 25 \text{ kN/m}^3) \times 1.5 = 4.096 \approx 4.1 \text{ kN/m}$
- Factored live load = 30 kN/m

Total Factored load $W_u = 34.1 \text{ kN/m} \approx 35 \text{ kN/m}$

$$\text{Factored moment } M_u = \frac{W_u \times l_e^2}{2} = \frac{35 \times 2.115^2}{2} = 78.28 \text{ kN-m}$$

Factored shear = $35 \times 2.115 = 74.025 \text{ kN}$

Step 4: Check for depth based on flexure or bending moment consideration

Assuming the section to be nearly balanced, and equating M_u to $M_{u\text{lim}}$,

$$M_u = M_{u\text{lim}} = 78.28 \text{ kN-m}$$

Using the equation G 1.1 (c)

$$M_{ulim} = 0.36 \frac{x_{umax}}{d} \left(1 - 0.42 \frac{x_{umax}}{d}\right) b d^2 f_{ck}$$

$$78.28 \times 10^6 = 0.36 \times 0.48 (1 - 0.42 \times 0.48) 230 d^2 \times 20$$

$$d = 222 \text{ mm}$$

$$d_{assumed} > d_{required}$$

Hence ok.

Step 5: Calculation of steel

Since the section is under reinforced we have,

Using equation G 1.1 (b)

$$M_u = 0.87 f_y A_{st} d \left(1 - \frac{A_{st} f_y}{b d f_{ck}}\right)$$

$$78.28 \times 10^6 = 0.87 \times 415 \times A_{st} \times 450 \left(1 - \frac{A_{st} \times 415}{230 \times 450 \times 20}\right)$$

$$\text{Solving the quadratic equation, } A_{st} = 540.33 \text{ mm}^2 \approx 540 \text{ mm}^2$$

Choosing 16 mm diameter bars,

$$\text{Area of 1 bar} = \frac{\pi}{4} \times 16^2 = 201.06 \text{ mm}^2$$

$$\text{Therefore number of bars of } 16\text{mm required} = 2.69 = 3 \text{ bars}$$

Distance between any two bars

Minimum distance between two bars is greater of the following:

- Size of the aggregate + 5 mm
20 mm + 5 mm
- Size of the bar (whichever is greater)=16mm

Therefore minimum distance = 25 mm

$$\text{Distance between the bars} = \frac{230 - 2 \times 25 - 2 \times 16 - 2 \times 8}{2} = 58 \text{ mm}$$

Distance provided = 58mm > Minimum distance 25mm

Hence ok.

Check for $A_{st \min}$

$$A_{st \min} = \frac{0.85bd}{0.87f_y}$$

$$A_{st \min} = \frac{0.85 \times 230 \times 450}{0.87 \times 415} = 243.66 \text{ mm}^2$$

$$A_{st \text{ provided}} = 3 \times \frac{\pi}{4} \times 16^2 = 603.18 \text{ mm}^2 > A_{st \min}$$

Hence ok.

Check for $A_{st \max}$

$$A_{st \max} = 0.04 \times b \times D = 4370 \text{ mm}^2$$

$$A_{st \text{ provided}} = 603.18 \text{ mm}^2$$

$$A_{st \min} < A_{st} < A_{st \max}$$

Hence ok.

Check for shear

$$V_u = 74.025 \text{ kN}$$

$$\tau_v = \frac{V_u}{bd} = 0.715 \text{ N/mm}^2$$

$$P_t = \frac{100A_{st}}{bd} = \frac{100 \times 603.18}{230 \times 450} = 0.58$$

From table 19,

$$\tau_c = 0.51 \text{ N/mm}^2$$

From table 20,

$$\tau_{c \max} = 2.8 \text{ N/mm}^2$$

$$\tau_c < \tau_v < \tau_{c \max}$$

Hence design of shear reinforcement is required

Selecting 2 leg vertical stirrups of 8 mm diameter, Fe 415 steel,

$$A_{sv} = 2 \times \frac{\pi}{4} \times 8^2 = 100 \text{ mm}^2$$

V_c = Shear force taken up by the concrete

$$= \frac{\tau_c bd}{1000} = \frac{0.51 \times 230 \times 450}{1000} = 52.78 \text{ kN}$$

$$V_u = 74.025 \text{ kN}$$

$$V_{us} = V_u - V_c$$

$$= 74.025 - 52.785 = 21.24 \text{ kN}$$

$$V_{us} = \frac{0.87 \times f_y \times A_{sv} \times d}{S_v}$$

$$21.24 \times 10^3 = \frac{0.87 \times 415 \times 100 \times 450}{S_v}$$

$$S_v = 764 \text{ mm}$$

Check for maximum spacing

Maximum spacing = 0.75d or 300mm whichever is lesser

Maximum spacing = 337.5 or 300mm

Therefore maximum spacing allowed = 300mm

Let us provide 8 mm dia 2-leg vertical stirrups at a spacing of 300 mm.

Check for $A_{sv \text{ min}}$:

$$A_{sv \text{ provided}} = 100 \text{ mm}^2$$

$$A_{sv \text{ min}} = \frac{0.4bS_v}{0.87f_y} = 76.44 \text{ mm}^2$$

$$A_{sv \text{ provided}} > A_{sv \text{ min}}$$

Hence ok.

Check for deflection:

$$\text{Allowable } \frac{l}{d} = \text{Basic } \frac{l}{d} \times M_t \times M_c \times M_f$$

$$\text{Basic } \frac{l}{d} = 7 \text{ as the beam is cantilever}$$

From fig 4, $M_t = 1.2$

From fig 5, $M_c = 1$

From fig 6, $\frac{b_w}{b_f} = 1$ [Since it is rectangular section $b_w = b_f$]

Therefore allowable $l/d = 7 \times 1.2 \times 1 \times 1 = 8.4$

Actual $l/d = \frac{2115}{450} = 4.7 < \text{Allowable } l/d$. Hence ok.

3. Design a reinforced concrete beam of rectangular section using the following data:

Effective span	= 5 m
Width of beam	= 250 mm
Overall depth	= 500 mm
Service load (DL+LL)	= 40 kN/m
Effective cover	= 50 mm
Materials	: M20 grade concrete and Fe 415 steel

a. Data

$b = 250 \text{ mm}$	$f_{ck} = 20 \text{ N/mm}^2$
$D = 500 \text{ mm}$	$f_y = 415 \text{ N/mm}^2$
$d = 450 \text{ mm}$	$E_s = 2 \times 10^5 \text{ N/mm}^2$
$d' = 50 \text{ mm}$	
$l_e = 5 \text{ m}$	
$w = 40 \text{ kN/m}$ and $W_u = 40 \times 1.5 = 60 \text{ kN/m}$	

b. Ultimate moments and shear forces

$$M_u = \frac{W_u \times l_e^2}{8} = \frac{60 \times 5^2}{8} = 187.5 \text{ kN-m}$$

$$V_u = \text{Factored shear} = \frac{W_u \times l_e}{2} = 150 \text{ kN}$$

c. Determination of $M_{u \text{ lim}}$ and f_{sc}

$$M_{u \text{ lim}} = 0.36 \frac{x_{u \text{ max}}}{d} \left(1 - 0.42 \frac{x_{u \text{ max}}}{d} \right) b d^2 f_{ck}$$

$$M_{u \text{ lim}} = 0.36 \times 0.48 (1 - 0.42 \times 0.48) 250 \times 450^2 \times 20$$

$$= 140 \text{ kN.m}$$

Since $M_u > M_{u \text{ lim}}$, design a doubly reinforced section

$$(M_u - M_{u \text{ lim}}) = 187.5 - 140 = 47.5 \text{ kN.m}$$

$$f_{sc} = \epsilon_{sc} \times E_s$$

$$\text{Where, } \epsilon_{sc} = \left\{ \frac{0.0035(x_{u \text{ max}} - d')}{x_{u \text{ max}}} \right\}$$

$$f_{sc} = \left\{ \frac{0.0035(x_{u \text{ max}} - d')}{x_{u \text{ max}}} \right\} E_s$$

$$= \left\{ \frac{0.0035[(0.48 \times 450) - 50]}{0.48 \times 450} \right\} 2 \times 10^5$$

$$= 538 \text{ N/mm}^2$$

But $f_{sc} \geq 0.87f_y = (0.87 \times 415) = 361 \text{ N/mm}^2$

Therefore $f_{sc} = 361 \text{ N/mm}^2$

$$\text{steel } A_{sc} = \left[\frac{(M_u - M_{u \text{ lim}})}{f_{sc}(d - d')} \right]$$

$$= \left[\frac{(47.5 \times 10^6)}{361 \times 400} \right] = 329 \text{ mm}^2$$

Provide 2 bars of 16mm diameter ($A_{sc} = 402 \text{ mm}^2$)

$$A_{st2} = \left(\frac{A_{sc} f_{sc}}{0.87 f_y} \right) = \left(\frac{329 \times 361}{0.87 \times 415} \right) = 329 \text{ mm}^2$$

$$A_{st1} = \left[\frac{0.36 f_{ck} b x_{u \text{ lim}}}{0.87 f_y} \right]$$

$$= \left[\frac{0.36 \times 20 \times 250 \times 0.48 \times 450}{0.87 \times 415} \right] = 1077 \text{ mm}^2$$

Total tension reinforcement = $A_{st} = (A_{st1} + A_{st2})$

$$= (1077 + 329)$$

$$= 1406 \text{ mm}^2$$

Provide 3 bars of 25mm diameter ($A_{st} = 1473 \text{ mm}^2$)

d. Shear reinforcements

$$\tau_v = (V_u / bd) = (150 \times 10^3) / (250 \times 450) = 1.33 \text{ N/mm}^2$$

$$P_t = \frac{(100 A_s)}{bd} = \frac{100 \times 1473}{250 \times 450} = 1.3$$

Referring table 19 of IS : 456 – 2000 ,

$$\tau_c = 0.68 \text{ N/mm}^2$$

$$\tau_{cmax} = 2.8 \text{ N/mm}^2 \text{ for M20 concrete from table 20 of IS 456-2000}$$

Since $\tau_c < \tau_v < \tau_{cmax}$, shear reinforcements are required.

$$V_{us} = [V_u - (\tau_c bd)]$$

$$= [150 - (0.68 \times 250 \times 450) 10^{-3}] = 73.5 \text{ kN}$$

Using 8 mm diameter 2 legged stirrups,

$$S_v = \frac{0.87 \times f_y \times A_{sv} \times d}{V_{us}} = \frac{0.87 \times 415 \times 2 \times 50 \times 450}{73.5 \times 10^3} = 221 \text{ mm}$$

Maximum spacing is 0.75d or 300 mm whichever is less

$$S_v > 0.75d = (0.75 \times 450) = 337.5 \text{ mm}$$

Adopt a spacing of 200 mm near supports gradually increasing to 300 mm towards the centre of the span.

e. Check for deflection control

$$(l/d)_{\text{actual}} = (5000/450) = 11.1$$

$$(l/d)_{\text{allowable}} = [(l/d)_{\text{basic}} \times M_t \times M_c \times M_f]$$

$$P_t = 1.3 \text{ and } P_c = [(100 \times 402) / (250 \times 450)] = 0.35$$

Refer Fig 4, $M_t = 0.93$

Fig 5, $M_c = 1.10$

Fig 6, $M_f = 1.0$

$$(l/d)_{\text{allowable}} = [(20 \times 0.93 \times 1.10 \times 1)] = 20.46$$

$$(l/d)_{\text{actual}} < (l/d)_{\text{allowable}}$$

Hence deflection control is satisfied.

f. Reinforcement details

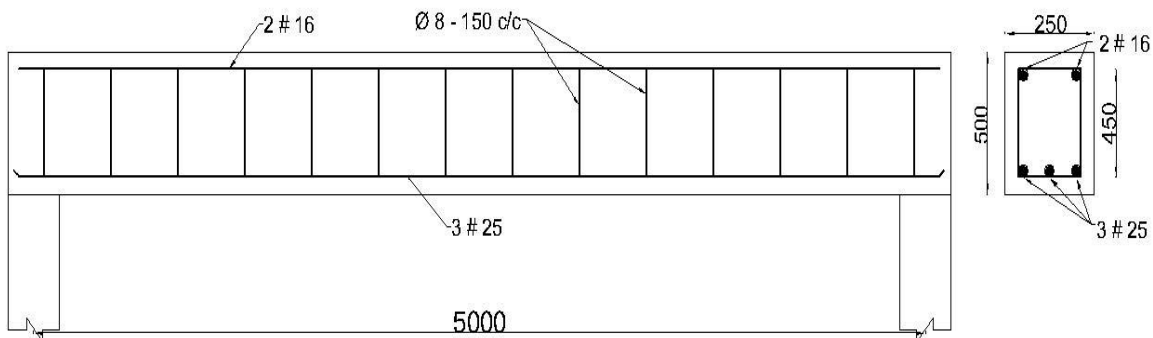

4. A tee beam slab floor of an office comprises of a slab 150 mm thick spanning between ribs spaced at 3m centres. The effective span of the beam is 8 m. Live load on floor is 4 kN/m^2 . Using M-20 grade concrete and Fe-415 HYSD bars, design one of the intermediate tee beam.

a. Data

$$\begin{array}{ll} L = 8 \text{ m} & \text{spacing of the tee beam} = 8 \text{ m} \\ D_f = 150 \text{ mm} & f_{ck} = 20 \text{ N/mm}^2 \\ \text{Live load on slab} = 4 \text{ kN/m}^2 & f_y = 415 \text{ N/mm}^2 \end{array}$$

b. Cross sectional dimensions

$$\text{Assume } \frac{l}{d} = 16$$

$$\text{Therefore } d = 500 \text{ mm and } D = 550 \text{ mm}$$

Hence the tee beam parameters are:

$$d = 500 \text{ mm}$$

$$D = 550 \text{ mm}$$

$$b_w = 300 \text{ mm}$$

$$D_f = 150 \text{ mm}$$

c. Loads

Self weight of slab	= (0.15 x 25 x 3)	= 11.25 kN/m
Floor finish	= (0.6 x 3)	= 1.80
Self weight of rib	= (0.3 x 0.4 x 25)	= 3.00
Plaster finishes	=	= 0.45
Total dead load	=	= 16.50 kN/m
Live load	=	= 4.00 kN/m

$$\text{Design ultimate load } W_u = 1.5(16.50+4.0) = 30.75 \text{ kN/m}$$

d. Ultimate moments and shear forces:

$$M_u = \frac{W_u \times l^2}{8} = \frac{30.75 \times 8^2}{8} = 246 \text{ kN-m}$$

$$V_u = \frac{W_u \times l}{2} = 123 \text{ kN}$$

e. Effective width of flange

$$\begin{aligned} \text{i. } b_f &= [(L_0/6) + b_w + 6 D_f] \\ &= [(8/6) + 0.3 + (6 \times 0.15)] \end{aligned}$$

$$= 2.53 \text{ m}$$

$$= 2530 \text{ mm}$$

- ii. Centre to centre of ribs = $(3-0.3) = 2.7 \text{ m}$
Hence the least of i and ii is $b_f = 2530 \text{ mm}$

f. Moment capacity of flange

$$M_{uf} = 0.36 f_{ck} b_f D_f (d-0.42 D_f)$$

$$= 0.36 \times 20 \times 2530 \times 150 (500-0.42 \times 150)$$

$$= 1194 \times 10^6 \text{ N.mm}$$

$$= 1194 \text{ kNm}$$

Since $M_u < M_{uf}$, $x_u < D_f$

Hence the section is considered as rectangular with $b = b_f$

g. Reinforcements

$$M_u = 0.87 f_y A_{st} d \left(1 - \frac{A_{st} f_y}{b_f d f_{ck}} \right)$$

$$246 \times 10^6 = 0.87 \times 415 A_{st} \times 500 \left(1 - \frac{415 A_{st}}{2530 \times 500 \times 20} \right)$$

$$\text{Solving, } A_{st} = 1417 \text{ mm}^2$$

Provide 3 bars of 25 mm diameter ($A_{st} = 1473 \text{ mm}^2$) and two hanger bars of 12 mm diameter on the compression face.

h. Shear reinforcements

$$\tau_v = (V_u / b_w d) = (123 \times 10^3) / (300 \times 500) = 0.82 \text{ N/mm}^2$$

$$P_t = \frac{(100 A_{st})}{b_w d} = \frac{100 \times 1473}{300 \times 500} = 0.98$$

Referring table 19 of IS : 456 – 2000 ,

$$\tau_c = 0.60 \text{ N/mm}^2$$

Since $\tau_v > \tau_c$, shear reinforcements are required.

$$V_{us} = [V_u - (\tau_c b_w d)]$$

$$= [123 - (0.60 \times 300 \times 500) 10^{-3}] = 33 \text{ kN}$$

Using 8 mm diameter 2 legged stirrups,

$$S_v = \frac{0.87 \times f_y \times A_{sv} \times d}{V_{us}} = \frac{0.87 \times 415 \times 2 \times 50 \times 500}{33 \times 10^3} = 547 \text{ mm}$$

Maximum spacing is 0.75d or 300 mm whichever is less

$$S_v > 0.75d = (0.75 \times 500) = 375 \text{ mm}$$

Hence provide 8 mm diameter 2 legged stirrups at 300 mm centres throughout the length of the beam.

i. Check for deflection control

$$P_t = \frac{(100A_{st})}{b_w d} = \frac{100 \times 1473}{300 \times 500} = 0.98$$

$$\left(\frac{b_w}{b_f}\right) = \left(\frac{300}{2530}\right) = 0.118$$

Refer Fig 4, and read out $M_t = 2.00$

Fig 5, and read out $M_c = 1.00$

Fig 6, and read out $M_f = 0.80$

$$(L/d)_{\max} = [(L/d)_{\text{basic}} \times M_t \times M_c \times M_f]$$

$$= [16 \times 2 \times 1 \times 0.8] = 25.6$$

$$(L/d)_{\text{provided}} = (8000/500) = 16 < 25.6$$

Hence deflection control is satisfied

j. Reinforcement details

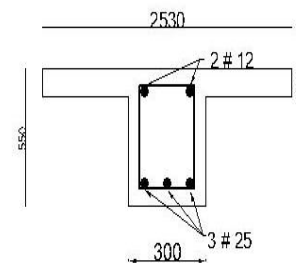
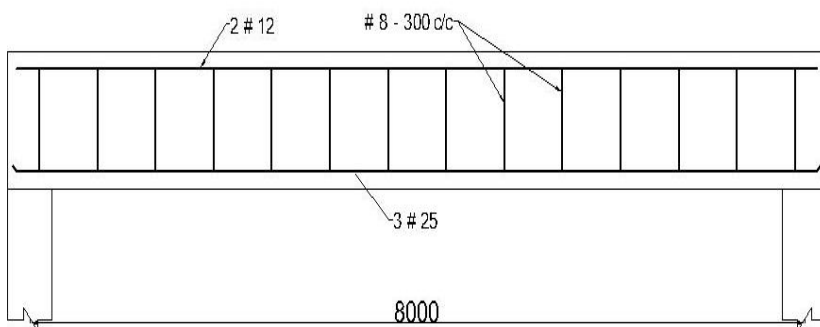

5. Design a L beam for an office floor to suit the following data:

Data

Clear span = $L = 8\text{ m}$

Thickness of flange = $D_f = 150\text{ mm}$

Live load on the slab = 4 kN/m^2

Spacing of beams = 3 m

$f_{ck} = 20\text{ N/mm}^2$

$f_y = 415\text{ N/mm}^2$

L-beams are monolithic with R.C columns

Width of column = 300 mm

Cross sectional dimensions

Since L-beam is subjected to bending, torsion and shear forces, assume a trial section having span/depth ratio of 12.

Therefore 'd' = $(8000/12) = 666\text{ mm}$

Adopt $d = 700\text{ mm}$

$D = 750\text{ mm}$

$b_w = 300\text{ mm}$

Effective span

Effective span is least of

i. Centre to centre of supports = $(8+0.3) = 8.3\text{ m}$

ii. Clear span + effective depth = $(8+0.7) = 8.7\text{ m}$

Therefore $L = 8.3\text{ m}$

Loads

Self weight of slab = $(0.15 \times 25 \times 0.5 \times 3) = 11.25\text{ kN/m}$

Floor finish = $(0.6 \times 0.5 \times 3) = 1.80$

Self weight of rib = $(0.3 \times 0.6 \times 25) = 3.00$

Live load = $(4 \times 0.5 \times 3) = 6.00\text{ kN/m}$

Total working load = $w = 17\text{ kN/m}$

Effective flange width

Effective flange width b_f is least of the following values:

- i. $b_f = (L_0/12) + b_w + 3D_f$
 $= (8000/12) + 300 + (3 \times 150) = 1442$
- ii. $b_f = b_w + 0.5$ times the spacing between the ribs
 $= 300 + (0.5 \times 2700) = 1650$ mm
Therefore $b_f = 1442$ mm

Ultimate bending and shear force

At support section:

$$M_u = 1.5 (17 \times 8.3^2) / 12 = 147 \text{ kN.m}$$

$$V_u = 1.5 (0.5 \times 17 \times 8.3) = 106 \text{ kN}$$

At centre of the span section:

$$M_u = 1.5 (17 \times 8.3^2) / 24 = 73 \text{ kN.m}$$

Torsional moments at support section

Torsional moment is produced due to dead load of slab and live load on it.

$$(\text{working load/m} - \text{rib self weight}) = (17 - 4.50) = 12.50 \text{ kN/m}$$

Therefore total ultimate load on slab = $1.5 (12.50 \times 8.3) = 156$ kN

$$\text{Total ultimate shear force} = (0.5 \times 156) = 78 \text{ kN}$$

Distance of centroid of shear force from the centre line of the beam

$$= (0.5 \times 1442 - 150) = 571 \text{ mm} = 0.571 \text{ m}$$

$$\text{Ultimate torsional moment} = T_u = 78 \times 0.571 = 44.5 \text{ kN.m}$$

Equivalent bending moment and shear force

According to IS : 456 – 2000, clause 41.4.2, at support section, the equivalent bending moment is compared as:

$$M_{el} = (M_u + M_t)$$

$$\text{Where, } M_t = T_u = \left[\frac{1+(D/b)}{1.7} \right] = 44.5 \left[\frac{1+(750/300)}{1.7} \right]$$

$$= 92 \text{ kN.m}$$

$$\text{Therefore } M_{el} = (147 + 92) = 239 \text{ kN.m}$$

$$\begin{aligned}
V_e &= V_u + 1.6 (T_u / b) \\
&= 106 + 1.6 (44.5/0.3) \\
&= 334 \text{ kN}
\end{aligned}$$

Main longitudinal reinforcement

Support section is designed as rectangular section to resist the hogging equivalent bending moment $M_{el} = 239 \text{ kN.m}$

$$\begin{aligned}
M_{u \text{ lim}} &= 0.138 f_{ck} b d^2 \\
&= (0.138 \times 20 \times 300 \times 700^2) 10^{-6} \\
&= 405.7 \text{ kN.m}
\end{aligned}$$

Since $M_{el} < M_{u \text{ lim}}$, the section is under reinforced.

$$M_{el} = 0.87 f_y A_{st} d \left(1 - \frac{A_{st} f_y}{b d f_{ck}} \right)$$

$$239 \times 10^6 = 0.87 \times 415 A_{st} \times 700 \left(1 - \frac{415 A_{st}}{300 \times 700 \times 20} \right)$$

$$\text{Solving, } A_{st} = 1056.3 \text{ mm}^2$$

Provide 3 bars of 22 mm diameter on the tension side ($A_{st} = 1140 \text{ mm}^2$)

Area of steel required at centre of span to resist a moment of $M_u = 73 \text{ kN.m}$ will be less than the minimum given by:

$$\begin{aligned}
A_{st \text{ (min)}} &= \left(\frac{0.85 b_w d}{f_y} \right) = \left(\frac{0.85 \times 300 \times 700}{415} \right) \\
&= 430 \text{ mm}^2
\end{aligned}$$

Provide 2 bars of 20 mm diameter ($A_{st} = 628 \text{ mm}^2$)

Side face reinforcement

According to clause 26.5.1.7 of IS : 456 code, side face reinforcement of 0.1 percent of web area is to be provided for member subjected to torsion, when the depth exceeds 450 mm.

$$\text{Therefore area of reinforcement} = (0.001 \times 300 \times 750) = 225 \text{ mm}^2$$

Provide 10 mm diameter bars (4 numbers) two on each face as horizontal reinforcement spaced 200 mm centres.

Shear reinforcements

$$\tau_{ve} = \left(\frac{V_e}{b_w d} \right) = \left(\frac{344 \times 10^3}{300 \times 700} \right) = 1.63 \text{ N/mm}^2$$

$$P_t = \frac{(100 A_{st})}{b_w d} = \frac{100 \times 1140}{300 \times 700} = 0.542$$

From table 19 IS:456 read out,

$$\tau_c = 0.49 \text{ N/mm}^2 < \tau_{ve}$$

Hence shear reinforcements are required.

Using 10 mm diameter two legged stirrups with side covers of 25 mm and top and bottom covers of 50 mm, we have $b_1 = 250 \text{ mm}$, $d_1 = 650 \text{ mm}$, $A_{sv} = (2 \times 78.5) = 157 \text{ N/mm}^2$

The spacing S_v is computed using the equations specified in clause 451.4.3 of IS : 456-2000 code.

$$\begin{aligned} S_v &= \left[\frac{0.87 f_y A_{sv} d_1}{\left(\frac{T_u}{b_1} \right) + \left(\frac{V_u}{2.5} \right)} \right] \\ &= \left[\frac{0.87 \times 415 \times 157 \times 650}{\left(\frac{44.5 \times 10^6}{250} \right) + \left(\frac{106 \times 10^3}{2.5} \right)} \right] \\ &= 167 \text{ mm} \end{aligned}$$

OR

$$\begin{aligned} S_v &= \left[\frac{0.87 A_{sv} f_y}{(\tau_{ve} - \tau_c) n} \right] \\ &= \left[\frac{0.87 \times 157 \times 415}{(1.63 - 0.49) 300} \right] \\ &= 165 \text{ mm} \end{aligned}$$

Provide 10 mm diameter two legged stirrups at a minimum spacing given by clause 26.5.1.7 of IS 456

Adopt a minimum spacing based on shear and torsion computations computed as $S_v = 160 \text{ mm}$.

Check for deflection control

$$P_t = \frac{100 \times 1140}{300 \times 700} = 0.54$$

$$P_c = \frac{100 \times 628}{300 \times 700} = 0.299$$

$$\left(\frac{b_w}{b_f}\right) = \left(\frac{300}{1442}\right) = 0.208$$

Refer Fig 4, and read out $M_t = 1.20$

Fig 5, and read out $M_c = 1.10$

Fig 6, and read out $M_f = 0.80$

$$(L/d)_{\max} = [(L/d)_{\text{basic}} \times M_t \times M_c \times M_f]$$

$$= [9.20 \times 1.2 \times 1.1 \times 0.8] = 21.12$$

$$(L/d)_{\text{provided}} = (8300/700) = 11.85 < 21.12$$

Hence deflection control is satisfied.

Reinforcement details

